



鎂佳機械工業股份有限公司
MEGA MACHINE CO.,LTD.

台灣 · 41154 台中市太平區工業路180號
No.180, Industrial Road, Tai-ping District, Taichung City, 41154, Taiwan R. O. C.
www.bandsaw.com.tw
Tel:+886-4-22712877(Rep.) Fax: +886-4-22715016
E-Mail: sales@bandsaw.com.tw



Official Website



www.bandsaw.com.tw

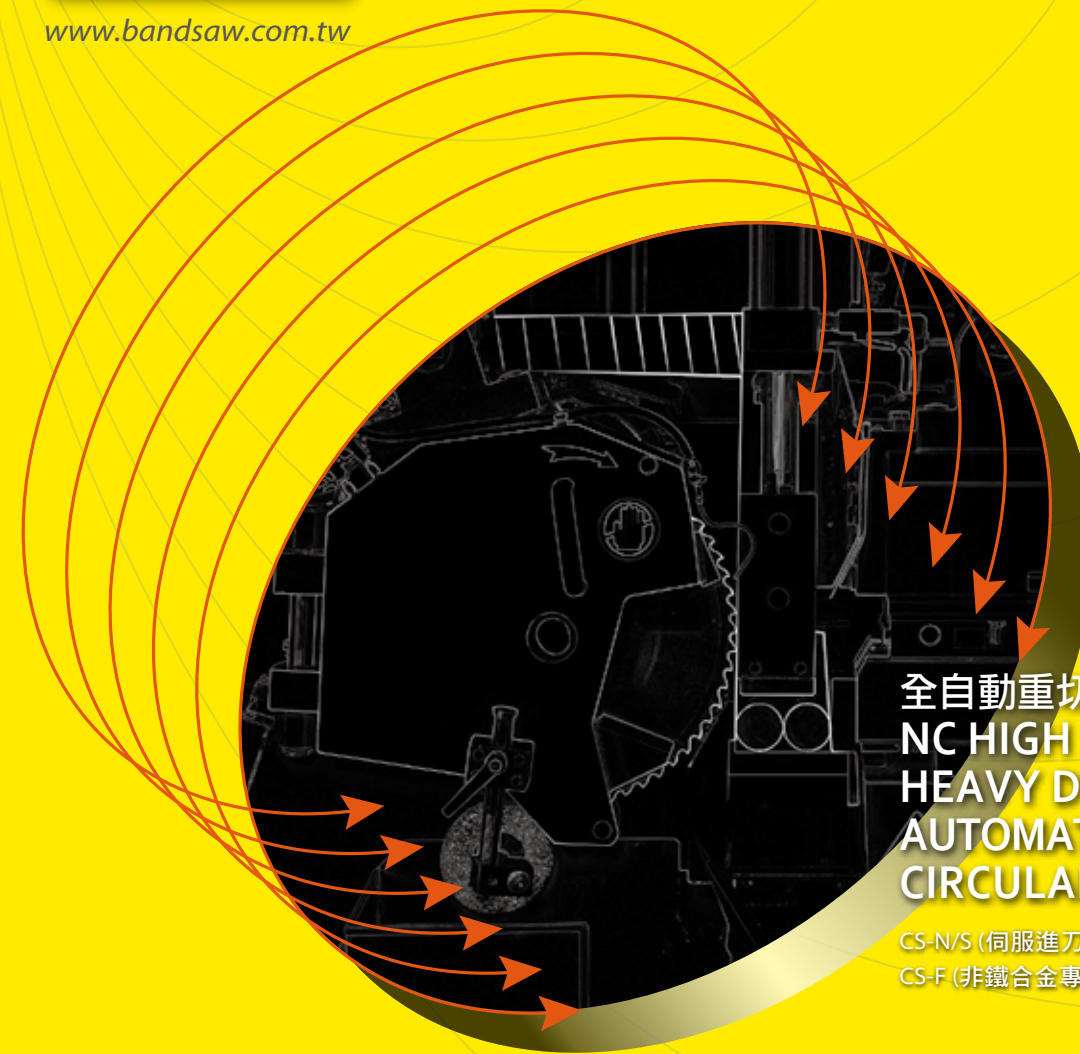

全自動重切削高速圓鋸機
NC HIGH SPEED
HEAVY DUTY
AUTOMATIC CARBIDE
CIRCULAR SAW

CS-N/S (伺服進刀 Servo Motor Feedrate)
CS-F (非鐵合金專用 Nonferrous Metal Cutting)

Keep Improving & Quality Oriented - Skillful engineering and imaginative design give every MEGA Circular Saw Machine exceptional cutting capacity.
不斷創新與精進&嚴格執行品質要求-以操作者為出發點的設計,並追求完美的品質

CS 系列特色 CS SERIES FEATURES	P3
機台外觀尺寸 MACHINE DIMENSIONS	P6
全自動重切削高速圓鋸機 (切鐵金屬) NC HIGH SPEED HEAVY DUTY AUTOMATIC CARBIDE CIRCULAR SAW (FERROUS METAL CUTTING)	P7
CS-75N/ 120N/ 120NX	P7
CS-75S	P9
CS-100S	P11
CS-150S	P13
全自動重切削高速圓鋸機 (切非鐵金屬) NC HIGH SPEED HEAVY DUTY AUTOMATIC CARBIDE CIRCULAR SAW (NONFERROUS METAL CUTTING)	P15
CS-75F	P15
CS-100F	P17
CS-150F	P19
選擇配備 OPTIONAL EQUIPMENT	P21



不斷創新與精進

今天做得要比昨天做得更好，明天做得要比今天做得還要好，是我們不斷創新，研究發展的精神所在。因為我們深知沒有成長就是退步，沒有創新就是落伍。鎂佳所以兢兢業業，奮發努力，為的是要提供經濟、完美的產品，貢獻業界來降低生產成本，減少胚料損失，提高生產能量，增進原胚料精度，提升自動化程度，促進技術升級，減少能源浪費。

嚴格執行品質要求

我們把機器當作是藝術品來處理，每個過程小心翼翼，要求盡善盡美，不容許有任何瑕疵。因為我們知道，為客戶提供完善快速的售後服務，不厭其煩的服務態度並不能使客戶完全滿足，唯有完美的品質，近乎免於服務的機器，才是我們追求的最大目標。

以操作者為出發點的設計

客戶的要求，操作者的願望，是本公司一系列機械設計的參考藍本，以機器來配合人們的操作，而不是以人來配合機器，正是我們全力追求的目標，因此，鎂佳的圓鋸機，結構剛強，操作容易，安全性高，鋸切能力強勁快速，精密度高，機件、鋸片持久耐用生產能量大，人工最省。

精良產品永續經營

鎂佳機械工業股份有限公司，創立於西元 1980 年，成立以全自動油壓帶鋸機、NC 全自動圓鋸機、精密油壓滾牙機、CNC 螺絲磨床之研發、製造、組裝及銷售服務的專業廠商。

KEEP IMPROVING

MEGA's R&D has over thirty-year experiences thus forms a strong team. It can provide total solution in screw and gear rolling, metal and nonferrous cutting, worm and thread grinding.

QUALITY ORIENTED

MEGA quality policy: "High performance and best quality can catch customers' heart, turning quality into company's "Super Salesman".

CUSTOMIZED FOR YOU

MEGA could provide total solution to meet your production requirement.

PERPETUAL MANAGEMENT

Since 1980,MEGA machine Co.,Ltd has been specializing in designing, producing and assembling, serving customers with bandsaw machine, NC circular saw machine, thread rolling machine and CNC thread grinding machine.

隨研發的改進，本公司保有設計變更產品規格的權力與解釋權，確定規格、尺寸、產品資訊以實品為準，若有變更恕不另行通知。Specifications are subject to change for improvement and modification without prior notice.

CS-N/ S/ F 全自動重切削高速圓鋸機

NC HIGH SPEED HEAVY DUTY AUTOMATIC CARBIDE CIRCULAR SAW

精準
PRECISE

機械電子整合控制 MECHATRONICS CONTROL

機械透過數值控制、伺服送料與進刀，並配合改良後的碳化鎢刀具，達到高速精密切削，切斷面平整的效果。High speed precision cutting with an almost ground finish surface and excellent repeatability has been made possible by numeric control, servo motor feeding cut-off and bar feed, and vastly improved carbide saw blade.

快速
FAST

更快的切削速度 CUTTING FASTER

CS-N、CS-S 系列 CS-N、CS-S Series

適用於一般鋼材，不銹鋼等，比傳統 HSS 鋸片的切削速度快達 5 倍。

Suitable for cutting most steels & alloys ranging from structural to stainless steels (SS,SC,SUS). Cutting speed is 5 times faster than machine with HSS blade.

CS-F 系列 CS-F Series

切非鐵類 (如鋁、銅、塑鋼) 專用機，鋸切速度比油壓切鋁機快 10 倍。

Designed especially for cutting nonferrous metal, such as aluminum alloy, copper, plastic steel. 10 times faster than cutting by machine with conventional HSS blade.

堅固
STABLE

鋸片壽命更長 ENHANCE BLADE SERVICE LIFE

堅固結構與防震設計提升切削速度並延長鋸片壽命。

Rigid structure and anti-vibration design ensure excellent and accurate repeatability with finishing cut surface for high-speed cutting and longer saw blade life.

輕薄
THIN

耗材更少 LESS MATERIAL CONSUMING

改良後的碳化鎢鋸片刀身更薄，耗材更少並可降低刀具磨耗，減低耗電量。

Vastly improved carbide saw blade is thinner, achieving less material consuming and resulting in less blade wear and less power consumption.



判別系統

自動化切削中自動分辨端材，殘材於不同料桶中。

SEPARATING SYSTEM

Separator automatically separates trim edge cut and residue into different storage tanks.



上壓夾鉗

切削單支或 2 支工件時，防止快速切削時衍生的震動。

OVERHEAD CLAMPING VISE JAW

Ensure material being clamped firmly and avoid vibration while fast cutting single bar or 2 pieces same size bar at one time.



鋸片防震裝置

使用電磁式煞車系統可防止震動、消除齒輪背隙，獲得良好鋸切面及延長刀具壽命。(CS-N/F 無此裝置)。

SAW BLADE ANTI VIBRATION DEVICE

Employs a unique electromagnetic brake system to eliminate vibration and sliding caused by gear backlash, ensuring a superb finish cut surface and enhancing blade service life. (N/A for CS-N/F)



油壓搖擺床座

配合伺服滾珠螺桿系統，能對彎曲工件良好運送，確保工件被切削時能達最小的磨耗以及最大的精度。

FLOATING SWIVELABLE REAR VISE SADDLE

This hydraulic floating rear vise saddle, linked to the servo motor and ball screw, is excellent for gripping and delivering even bowed or bent bar, ensuring minimum worn surface and greatest cutting accuracy.

CS-N/ S/ F 全自動重切削高速圓鋸機

NC HIGH SPEED HEAVY DUTY AUTOMATIC CARBIDE CIRCULAR SAW



獨特齒輪箱設計

獨特齒輪傳動系統設計確保切削過程平順無雜音，提高切削效能，減少耗電量，並可延長圓鋸片壽命。

UNIQUE GEAR HEAD DESIGN

The unique gear transmission system ensures smooth cutting with high efficiency, less noise, and low power consumption, and enhances saw blade service life.



模組化設計

獨立式油噴霧系統模組化，可自行設定控制間接或連續性噴霧時間，大幅節省切削油的使用，當切削油量不足時也將自動發出警示提醒。

UP TO DATE MODULE

Modularized oil mist spraying mode can be set as:

1. Intermittent spraying
2. Continuously spraying for optimized mist oil consumption. When the cutting oil is not enough, then error signal will pop-out to notify the operator to refill it.

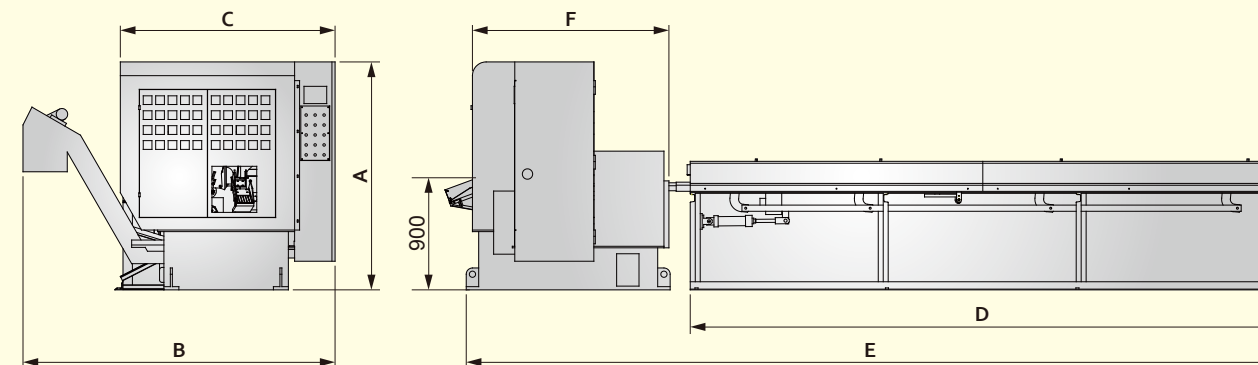

人機介面控制

1. 機電整合的人性化觸控螢幕。
2. 簡易設定各項數值與切削模式。
3. 多項安全偵測監控程式之設計，可顯示故障因素及維修對策。

TOUCH SCREEN CONTROL

It's a fuzzy, graphic, colorful, digital and tactile control panel, allowing easy presetting for various work-piece. It has an automatic detector display to indicate operational errors and causes of malfunctions.

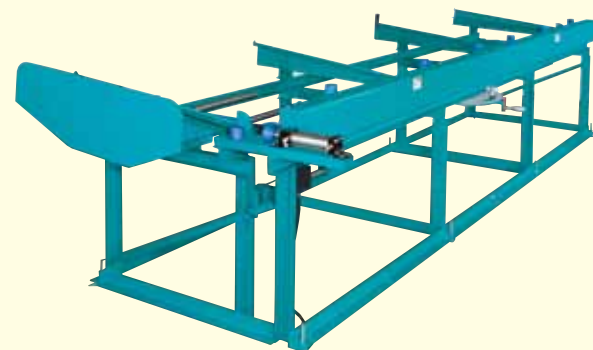

進料架

標準進料架能調整不同材料外徑大小，可放置材料長至6公尺。另可依進料需求客製尺寸與功能。

MAGAZINE TABLE

Magazine table holds 6 meters long material for loading different sizes of bars. Customized bar loading system is optional for different applications.

機型 MODEL	單位 UNIT	A	B	C	D	E	F
CS-75S/75F	mm	1830	2410	1720	4690	6500	1600
	inch	72	94.9	67.7	184.6	255.9	63
CS-100S/100F	mm	1840	2760	2025	4690	6500	1600
	inch	72.4	108.6	79.7	184.6	255.9	63
CS-150S/150F	mm	1855	2900	2160	4700	6940	1850
	inch	73	114.2	85.0	185	273.2	72.8

料架尺寸規格 MAGAZINE TABLE DIMENSIONS

規格 / 機型 SPEC. / MODEL	單位 UNIT	CS-75S/75F	CS-100S/100F	CS-150S/150F
承載能力 Capacity	mm	ø70 x 6000L x 13 支 pcs	ø100 x 6000L x 10 支 pcs	ø150 x 6000L x 6 支 pcs
	inch	ø2.76 x 236.2 x 13 支 pcs	ø3.93 x 236.2L x 10 支 pcs	ø5.91 x 236.2L x 6 支 pcs
料架尺寸 Size	mm	5300 L x 1600 W	5300 L x 1600 W	5300 L x 1400 W
	inch	208.66 L x 63 W	208.66 L x 63 W	208.66 L x 55 W

CS-75N/120N/120NX NEW EVOLUTION SERIES

NC 全自動切削高速圓鋸機

NC HIGH SPEED AUTOMATIC CARBIDE CIRCULAR SAW



規格表 Specifications

規格 / 機型	SPEC. / MODEL	UNIT	CS-75N	CS-120N/120NX
工作規格	Cutting Capacity	mm	● 10 ~ 75 ■ 15 ~ 60	● 20~120 ■ 20~85
		in	● 0.39 ~ 2.95 ■ 0.6 ~ 2.36	● 0.79~4.72 ■ 0.79~3.35
馬達馬力	Motor Output	hp	圓鋸驅動馬達 Blade -15/4P	圓鋸驅動馬達 Blade -20/4P
			油壓幫浦馬達 Hyd -2	油壓幫浦馬達 Hyd -3
			送伺服馬達 Bar Feed Servo -1.33	送伺服馬達 Bar Feed Servo -2.41
			進刀伺服馬達 Servo Feedrate -1.33	進刀伺服馬達 Servo Feedrate -1.74
鋸片尺寸	Blade Size	mm	Ø280 (Ø285) x Ø32 x T 2.0	Ø380 x Ø40 x T2.6; Z=60
		In	Ø11.02 (Ø11.22) x Ø1.26 x T 0.079	Ø14.96 x Ø1.57 x T0.102; Z=60
圓鋸迴轉速度	Blade Speed	rpm	56 → 225	50 → 150
			變頻無段可調 Inverter Controlled Variable Speed	變頻無段可調 Inverter Controlled Variable Speed
進刀方式	Blade Feed Cut	-	AC 伺服馬達+滾珠螺桿	AC Servo Motor And Ball Screw
送料方式	Bar Feed	-	AC 伺服馬達+滾珠螺桿	AC Servo Motor And Ball Screw
切斷長度	Auto Feed Length	mm	一次送料 Single Feed 6 ~ 600	一次送料 Single Feed 600 ~ 9999
		In	二次送料以上 Multiple Feed 600 ~ 9999	二次送料以上 Multiple Feed 23.62 ~ 393.60
自動清屑機構	Auto Chip Conveyor	-	鏈條驅動(選配)	Chain Belt Chip Conveyor (Optional)
冷卻系統	Cooling System	-	空氣壓縮油霧	Air Compressed Oil Mist
裝箱尺寸	Packing Size (L x W x H)	mm	2290 x 2240 x 2130	2290 x 3050 x 2150
		ft	7.51 x 7.35 x 6.99	7.51 x 10.01 x 7.05
裝箱重量	N.W / G.W	kg	2460 / 2950	3350 / 3940
		lb	5423 / 6503	7385 / 8686
料架尺寸規格 / Magazine Table Dimensions				
承載能力	Capacity	mm	Ø75 x 6000L x 13 支 pcs	Ø120 x 6000L x 8 支 pcs
		in	Ø2.95 x 236.2L x 13 支 pcs	Ø4.89 x 236.2L x 8 支 pcs
料架尺寸	Size	mm	5300L x 1600W	2850L x 2270W
		in	208.66L x 63W	112.2L x 89.37W

標準配備 Standard Equipment

圓鋸片 Saw blade	1 片 pc
鋼刷輪 Wire brush	2 個 pcs
工作燈 Working lamp	1 組 set
工具箱 Tools with tool box	1 組 set
操作手冊 Instruction manual	1 本 copy

選擇配備 Optional Equipment

1. 清屑機 Auto chip conveyor.
2. 接長料架 Long cut-off pieces unloading table.
3. 整把料架 Bar stock reservoir and loader.
4. 平板工件用之鏈條式料架 Chain belt magazine table for flat work-piece.

CS-75S 全自動重切削高速圓鋸機 (伺服進刀)

NC HIGH SPEED HEAVY DUTY AUTOMATIC CARBIDE CIRCULAR SAW (SERVO MOTOR FEEDRATE)



規格表 Specifications

規格 / 機型 SPEC. / MODEL	CS-75S	
工作規格 Cutting Capacity	mm	● 10 ~ 75 ■ 15 ~ 60
	in	● 0.39 ~ 2.95 ■ 0.6 ~ 2.36
馬達馬力 Motor Output	HP	圓鋸驅動馬達 Blade-10/4P, 油壓幫浦馬達 Hyd.-2 送料伺服馬達 Bar Feed Servo-0.65 進刀伺服馬達 Servo Feedrate -1.13
	KW	圓鋸驅動馬達 Blade-7.5, 油壓幫浦馬達 Hyd.-1.5 送料伺服馬達 Bar Feed Servo-0.5 進刀伺服馬達 Servo Feedrate -0.85
鋸片尺寸 Blade Size	mm	φ280(285) X φ32 X T 2.0
	in	φ11.0(11.2) X φ1.26 X T 0.079
圓鋸迴轉速度 Blade Speed	rpm	90 - 130
進刀方式 Blade Feed Cut	.	AC 伺服馬達 + 滾珠螺桿 AC Servo Motor + Ball Screw
送料方式 Bar Feed	.	AC 伺服馬達 + 滾珠螺桿 AC Servo Motor + Ball Screw
切斷長度 Auto Feed Length	mm	一次送料 Single Feed 6~600 / 二次送料以上 Multiple Feed 600~9999
	in	一次送料 Single Feed 0.23~23.62 / 二次送料以上 Multiple Feed 23.62~393.6
自動清屑機構 Auto Chip Conveyor	.	鏈條驅動 (選配) Chain Belt Chip Conveyor (Opt.)
冷卻系統 Cooling System	.	空氣壓縮油霧 Air Compressed Oil Mist
裝箱尺寸 Packing Size (L X W X H)	mm	2290 X 2240 X 2130
	ft	7.51 X 7.35 X 6.99
裝箱重量 N.W. / G.W.	kg	2130 / 2375 (底板裝 With Pallets)
	lb	4686 / 5225 (底板裝 With Pallets)

標準配備 Standard Equipment

圓鋸片 Saw blade	1 片 pc
鋼刷輪 Wire brush	2 個 pcs
工作燈 Working lamp	1 組 set
工具箱 Tools with tool box	1 組 set
操作手冊 Instruction manual	1 本 copy

選擇配備 Optional Equipment

1. 清屑機 Auto chip conveyor.
2. 接長料架 Long cut-off pieces unloading table.
3. 整把料架 Bar stock reservoir and loader.
4. 平板工件用之鏈條式料架 Chain belt magazine table for flat work-piece.

CS-100S 全自動重切削高速圓鋸機 (伺服進刀)

NC HIGH SPEED HEAVY DUTY AUTOMATIC CARBIDE CIRCULAR SAW (SERVO MOTOR FEEDRATE)



規格表 Specifications

規格 / 機型 SPEC. / MODEL	CS-100S	
工作規格 Cutting Capacity	mm	● 16 ~ 100 (110) ■ 20 ~ 80(85)
	in	● 0.63~3.93 (4.33) ■ 0.78~3.15 (3.35)
馬達馬力 Motor Output	HP	圓鋸驅動馬達 Blade-15/4P 油壓幫浦馬達 Hyd.-2 送料伺服馬達 Bar Feed Servo -1.13 進刀伺服馬達 Servo Feedrate-1.73
	KW	圓鋸驅動馬達 Blade-11 油壓幫浦馬達 Hyd.-1.5 送料伺服馬達 Bar Feed Servo -0.85 進刀伺服馬達 Servo Feedrate-1.3
鋸片尺寸 Blade Size	mm	φ360(380) X φ40 X T2.5
	in	φ14.1(14.9) X φ1.57 X T0.098
圓鋸迴轉速度 Blade Speed	rpm	70 - 130
進刀方式 Blade Feed Cut		AC 伺服馬達 + 滾珠螺桿 AC Servo Motor + Ball Screw
送料方式 Bar Feed		AC 伺服馬達 + 滾珠螺桿 AC Servo Motor + Ball Screw
切斷長度 Auto Feed Length	mm	一次送料 Single Feed 6~600 / 二次送料以上 Multiple Feed 600~9999
	in	一次送料 Single Feed 0.23~23.62 / 二次送料以上 Multiple Feed 23.62~393.6
自動清屑機構 Auto Chip Conveyor		鏈條驅動 (選配) Chain Belt Chip Conveyor (Opt.)
冷卻系統 Cooling System		空氣壓縮油霧 Air Compressed Oil Mist
裝箱尺寸 Packing Size (L X W X H)	mm	2550 X 2270 X 2260
	ft	8.36 X 7.45 X 7.41
裝箱重量 N.W. / G.W.	kg	2650 / 2850 (底板裝 With Pallets)
	lb	5830 / 6270 (底板裝 With Pallets)

標準配備 Standard Equipment

圓鋸片 Saw blade	1 片 pc
鋼刷輪 Wire brush	2 個 pcs
工作燈 Working lamp	1 組 set
工具箱 Tools with tool box	1 組 set
操作手冊 Instruction manual	1 本 copy

選擇配備 Optional Equipment

1. 清屑機 Auto chip conveyor.
2. 接長料架 Long cut-off pieces unloading table.
3. 整把料架 Bar stock reservoir and loader.
4. 平板工件用之鏈條式料架 Chain belt magazine table for flat work-piece.

CS-150S 全自動重切削高速圓鋸機 (伺服進刀)

NC HIGH SPEED HEAVY DUTY AUTOMATIC CARBIDE CIRCULAR SAW (SERVO MOTOR FEEDRATE)



規格表 Specifications

規格 / 機型 SPEC. / MODEL		CS-150S
工作規格 Cutting Capacity	mm	● 50 ~ 150 (160) ■ 70 ~ 110 (120)
	in	● 1.97 ~ 5.91 (6.3) ■ 2.75 ~ 4.33 (4.72)
馬達馬力 Motor Output	HP	圓鋸驅動馬達 Blade-20/6P 油壓幫浦馬達 Hyd.-3 送料伺服馬達 Bar Feed Servo -1.73 進刀伺服馬達 Servo Feedrate -1.73
	KW	圓鋸驅動馬達 Blade-15/6P 油壓幫浦馬達 Hyd.-2.23 送料伺服馬達 Bar Feed Servo -1.3 進刀伺服馬達 Servo Feedrate -1.3
鋸片尺寸 Blade Size	mm	ø460 (480) X ø50 X T2.7
	in	ø18.1 (18.9) X ø1.96 X T 0.106
圓鋸迴轉速度 Blade Speed	rpm	60 - 90
進刀方式 Blade Feed Cut	.	AC 伺服馬達 + 滾珠螺桿 AC Servo Motor + Ball Screw
送料方式 Bar Feed	.	AC 伺服馬達 + 滾珠螺桿 AC Servo Motor + Ball Screw
切斷長度 Auto Feed Length	mm	一次送料 Single Feed 6~600 / 二次送料以上 Multiple Feed 600~9999
	in	一次送料 Single Feed 0.23~23.62 / 二次送料以上 Multiple Feed 23.62~393.6
自動清屑機構 Auto Chip Conveyor	.	鏈條驅動 (選配) Chain Belt Chip Conveyor (Opt.)
冷卻系統 Cooling System	.	空氣壓縮油霧 Air Compressed Oil Mist
裝箱尺寸 Packing Size (L X W X H)	mm	2580 X 2270 X 2260
	ft	8.46 X 7.45 X 7.41
裝箱重量 N.W. / G.W.	kg	3650 / 3800 (底板裝 With Pallets)
	lb	8030 / 8360 (底板裝 With Pallets)

標準配備 Standard Equipment

圓鋸片 Saw blade	1 片 pc
鋼刷輪 Wire brush	2 個 pcs
工作燈 Working lamp	1 組 set
工具箱 Tools with tool box	1 組 set
操作手冊 Instruction manual	1 本 copy

選擇配備 Optional Equipment

1. 清屑機 Auto chip conveyor.
2. 接長料架 Long cut-off pieces unloading table.
3. 整把料架 Bar stock reservoir and loader.
4. 平板工件用之鏈條式料架 Chain belt magazine table for flat work-piece.

CS-75F 全自動重切削高速圓鋸機 (切非鐵金屬)

NC HIGH SPEED HEAVY DUTY AUTOMATIC CARBIDE CIRCULAR SAW (NONFERROUS METAL CUTTING)



規格表 Specifications

規格 / 機型 SPEC. / MODEL		CS-75F
工作規格 Cutting Capacity	mm	● 10 ~ 75 ■ 15 ~ 60
	in	● 0.39 ~ 2.95 ■ 0.6 ~ 2.36
馬達馬力 Motor Output	HP	圓鋸驅動馬達 Blade 10/2P 油壓幫浦馬達 Hydraulic Pump 2 送料伺服馬達 Bar feed Servo 0.65 進刀伺服馬達 Servo Feedrate 1.13 吸屑集塵機 Vacuum Chip Collector 1 (Opt.) 吹屑鼓風機 Debris Blower 0.5
	KW	圓鋸驅動馬達 Blade 7.5/2P 油壓幫浦馬達 Hydraulic Pump 1.5 送料伺服馬達 Bar feed Servo 0.5 進刀伺服馬達 Servo Feedrate 0.85 吸屑集塵機 Vacuum Chip Collector 0.75 (Opt.) 吹屑鼓風機 Debris Blower 0.38
鋸片尺寸 Blade Size	mm	ø305 X ø25.4 X T2.6
	in	ø12 X ø1 X T1.02
圓鋸迴轉速度 Blade Speed	rpm	3000 - 5500
進刀方式 Blade Feed Cut	.	AC 伺服馬達 + 滾珠螺桿 AC Servo Motor + Ball Screw
送料方式 Bar Feed	.	AC 伺服馬達 + 滾珠螺桿 AC Servo Motor + Ball Screw
切斷長度 Auto Feed Length	mm	一次送料 Single Feed 6~600 / 二次送料以上 Multiple Feed 600~9999
	in	一次送料 Single Feed 0.23~23.62 / 二次送料以上 Multiple Feed 23.62~393.6
自動清屑機構 Auto Chip Conveyor	.	鏈條驅動 + 吸屑集塵機 (選配) Chain Belt Chip Conveyor+ Vacuum Chip Collector (Opt.)
冷卻系統 Cooling System	.	空氣壓縮油霧 Air Compressed Oil Mist
裝箱尺寸 Packing Size (L X W X H)	mm	2290 X 2240 X 2130
	ft	7.51 X 7.35 X 6.99
裝箱重量 N.W. / G.W.	kg	2300 / 2450 (底板裝 With Pallets)
	lb	5060 / 5390 (底板裝 With Pallets)

標準配備 Standard Equipment

圓鋸片 Saw blade	1 片 pc
操作手冊 Instruction manual	1 本 copy
工作燈 Working lamp	1 組 set
工具箱 Tools with tool box	1 組 set

選擇配備 Optional Equipment

1. 清屑機及吸屑機 Auto chip conveyor and vacuum chip collector.
2. 接長料架 Long cut-off pieces unloading table.
3. 整把料架 Bar stock reservoir and loader.
4. 平板工件用之鏈條式料架 Chain belt magazine table for flat work-piece.

CS-100F 全自動重切削高速圓鋸機 (切非鐵金屬)

NC HIGH SPEED HEAVY DUTY AUTOMATIC CARBIDE CIRCULAR SAW (NONFERROUS METAL CUTTING)



規格表 Specifications

規格 / 機型 SPEC. / MODEL		CS-100F
工作規格 Cutting Capacity	mm	● 16 ~ 100 ■ 20 ~ 80
	in	● 0.63 ~ 3.93 ■ 0.78 ~ 3.15
馬達馬力 Motor Output	HP	油圓鋸驅動馬達 Blade 20/2P 油壓幫浦馬達 Hydraulic Pump 2 送料伺服馬達 Bar Feed Servo 1.13 進刀伺服馬達 Servo Feedrate 1.73 吸屑集塵機 Vacuum Chip Collector 3 (Opt.) 吹屑鼓風機 Debris Blower 0.5
	KW	圓鋸驅動馬達 Blade 15/2P 油壓幫浦馬達 Hydraulic Pump 1.5 送料伺服馬達 Bar feed Servo 0.85 進刀伺服馬達 Servo Feedrate 1.3 吸屑集塵機 Vacuum Chip Collector 2.23(Opt.) 吹屑鼓風機 Debris Blower 0.38
鋸片尺寸 Blade Size	mm	ø355 X ø25.4 X T3
	in	ø14 X ø1 X T0.11
圓鋸迴轉速度 Blade Speed	rpm	2500 - 4000
進刀方式 Blade Feed Cut	.	AC 伺服馬達 + 滾珠螺桿 AC Servo Motor + Ball Screw
送料方式 Bar Feed	.	AC 伺服馬達 + 滾珠螺桿 AC Servo Motor + Ball Screw
切斷長度 Auto Feed Length	mm	一次送料 Single Feed 6~600 / 二次送料以上 Multiple Feed 600~9999
	in	一次送料 Single Feed 0.23~23.62 / 二次送料以上 Multiple Feed 23.62~393.6
自動清屑機構 Auto Chip Conveyor	.	鏈條驅動 + 吸屑集塵機 (選配) Chain Belt Chip Conveyor+ Vacuum Chip Collector (Opt.)
冷卻系統 Cooling System	.	空氣壓縮油霧 Air Compressed Oil Mist
裝箱尺寸 Packing Size (L X W X H)	mm	2550X 2270 X 2260
	ft	8.37 X 7.45 X 7.41
裝箱重量 N.W. / G.W.	kg	2650 / 2800 (底板裝 With Pallets)
	lb	5830 / 6160 (底板裝 With Pallets)

標準配備 Standard Equipment

圓鋸片 Saw blade	1 片 pc
操作手冊 Instruction manual	1 本 copy
工作燈 Working lamp	1 組 set
工具箱 Tools with tool box	1 組 set

選擇配備 Optional Equipment

1. 清屑機及吸屑機 Auto chip conveyor and vacuum chip collector.
2. 接長料架 Long cut-off pieces unloading table.
3. 整把料架 Bar stock reservoir and loader.
4. 平板工件用之鏈條式料架 Chain belt magazine table for flat work-piece.

CS-150F 全自動重切削高速圓鋸機 (切非鐵金屬)

NC HIGH SPEED HEAVY DUTY AUTOMATIC CARBIDE CIRCULAR SAW (NONFERROUS METAL CUTTING)



規格表 Specifications

規格 / 機型 SPEC. / MODEL	CS-150F	
工作規格 Cutting Capacity	mm	● 50 ~ 150 ■ 70 ~ 110
	in	● 1.97 ~ 5.91 ■ 2.75 ~ 4.33
馬達馬力 Motor Output	HP	圓鋸驅動馬達 Blade 20/4P 油壓幫浦馬達 Hydraulic Pump 3 送料伺服馬達 Bar feed Servo 1.73 進刀伺服馬達 Servo Feedrate 1.73 吸屑集塵機 Vacuum Chip Collector 5 (Opt.) 吹屑鼓風機 Debris Blower 0.5
	KW	圓鋸驅動馬達 Blade 15/4P 油壓幫浦馬達 Hydraulic Pump 2.23 送料伺服馬達 Bar feed Servo 1.3 進刀伺服馬達 Servo Feedrate 1.3 吸屑集塵機 Vacuum Chip Collector 3.75(Opt.) 吹屑鼓風機 Debris Blower 0.38
鋸片尺寸 Blade Size	mm	ø455 X ø25.4 X T3.4
	in	ø17.9 X ø1 X T0.133
圓鋸迴轉速度 Blade Speed	rpm	1000 - 2100
進刀方式 Blade Feed Cut	.	AC 伺服馬達 + 滾珠螺桿 AC Servo Motor + Ball Screw
送料方式 Bar Feed	.	AC 伺服馬達 + 滾珠螺桿 AC Servo Motor + Ball Screw
切斷長度 Auto Feed Length	mm	一次送料 Single Feed 6~600 / 二次送料以上 Multiple Feed 600~9999
	in	一次送料 Single Feed 0.23~23.62 / 二次送料以上 Multiple Feed 23.62~393.6
自動清屑機構 Auto Chip Conveyor	.	鏈條驅動 + 吸屑集塵機 (選配) Chain Belt Chip Conveyor+ Vacuum Chip Collector (Opt.)
冷卻系統 Cooling System	.	空氣壓縮油霧 Air Compressed Oil Mist
裝箱尺寸 Packing Size (L X W X H)	mm	2580 X 2270 X 2260
	ft	8.46 X 7.45 X 7.41
裝箱重量 N.W. / G.W.	kg	3520 / 3670 (底板裝 With Pallets)
	lb	7744 / 8074 (底板裝 With Pallets)

標準配備 Standard Equipment

圓鋸片 Saw blade	1 片 pc
操作手冊 Instruction manual	1 本 copy
工作燈 Working lamp	1 組 set
工具箱 Tools with tool box	1 組 set

選擇配備 Optional Equipment

1. 清屑機及吸屑機 Auto chip conveyor and vacuum chip collector.
2. 接長料架 Long cut-off pieces unloading table.
3. 整把料架 Bar stock reservoir and loader.
4. 平板工件用之鏈條式料架 Chain belt magazine table for flat work-piece.

選擇配備 OPTIONAL EQUIPMENT

清潔鋸屑或油霧 CHIPS/OIL REMOVING AND CLEANING



自動清屑機構

機台處於自動循環切削時，自動清屑機構即能發揮最佳效率。

AUTO CHIP CONVEYOR

Conveys chips into waste tank for efficient chip cleaning during automatic cutting cycle.



油霧分離機

外型輕巧效率高，採離心式過濾，是最有效的油霧收集方式，使用此裝置可達到環境品質良好並顧及操作者健康和安全的需要。

MIST FILTER

Compact, highly efficient, with the most effective way of collecting oil mist, centrifugal filtration. The device satisfies the demand of environment friendly production and shows the concern for the operators' health and safety.



動力鋼刷輪

切削不鏽鋼工件或高黏度工件時清除鋸片上鐵屑可提高鋸片壽命。

POWER-DRIVEN WIRE BRUSH

It cleans chips that stick to the blade while cutting stainless steel or other adhesive metal so as to enhance the blade's service life.



鼓風除屑機

(僅適用於 CS-F 機種)

非鐵合金切削，如鋁合金工件。快速切削時大量碎屑飛濺搭配本機可快速清屑。

VACUUM CHIP COLLECTOR (Optional only for CS-F models)

Vacuum chip collector is suitable for nonferrous metal cutting such as aluminum alloy. It collects chips produced from fast cutting.

儲料架 / 進料架 / 出料架 LOADING AND UNLOADING

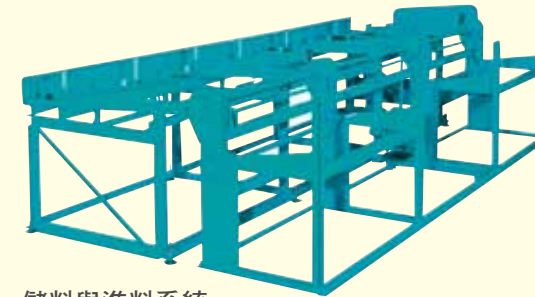

儲料與進料系統

可放置大量待切材料，適時自動補充工件於送料架上。自動化節省人力。*可依個別需求客製化

BAR STOCK RESERVOIR AND LOADER

Designed especially for stock work-piece. It delivers work-piece to magazine table automatically, which saves human power greatly. * Customization available.

鍊條或滾輪式出料架

依自動化生產需求，可搭配儲料桶或機械手臂使用。

UNLOADING TABLE

For various production demands, specifications are customized. Robotic arms are available for automatic unloading and unloading.

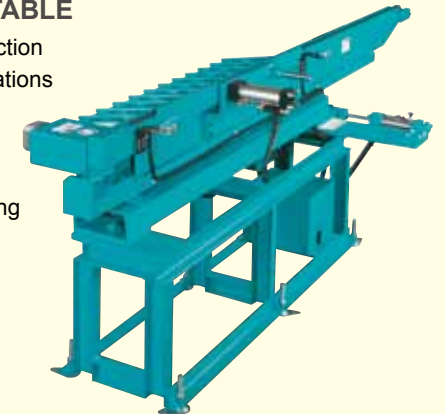

殘料縮短 / 薄鋸片 LESS MATERIAL CONSUMPTIONS



第三夾鉗

裝上第三夾鉗能讓工件殘料長度短於 30mm 以內。

AUXILIARY 3rd VISE

Residue length can be 30mm or less while a machine is installed with the third vise.



超薄鋸片

超薄鋸片比一般鋸片厚度減少 0.25mm，可大量減少碎屑，進一步達成省材料，節省能源之功效。

SUPER-THIN BLADE

It is 0.25mm thinner than normal one, which reduces material wastes and lowers cutting costs.